

# User manual

## BoxFan

### BF900R-500PA2371

#### With round air inlet and outlet

BoxFan is a fan with low energy consumption and low noise emission. It is ideal for moving air in new installations as well as for replacing existing fans when energy renovating or as spare part.

BoxFan consists of a box of warm-galvanized sheet metal, which are lined with 20 mm. insulation.

This ensures effective insulation against noise and condensation and makes it resistant to various climate impacts

Inside the box, the fan is mounted on a warm-galvanized sheet metal plate and this is accessed by removing the inspection hatch.

The fan itself is an EC fan with high efficiency. The motor has built-in electronics for stepless control, which can be controlled via potentiometer, pressure control or other equipment that can be purchased. See connection diagram.

On this motor, backward curved fan wheels are fitted. The wheel/impeller are of the RadiCal type, which is developed with high efficiency at the lowest possible noise levels in mind.

Thus, no additional parts are required to cause the fan to provide an energy-friendly and quiet function.

For more, go to [www.ebmpapst.dk](http://www.ebmpapst.dk)

Enjoy the product.

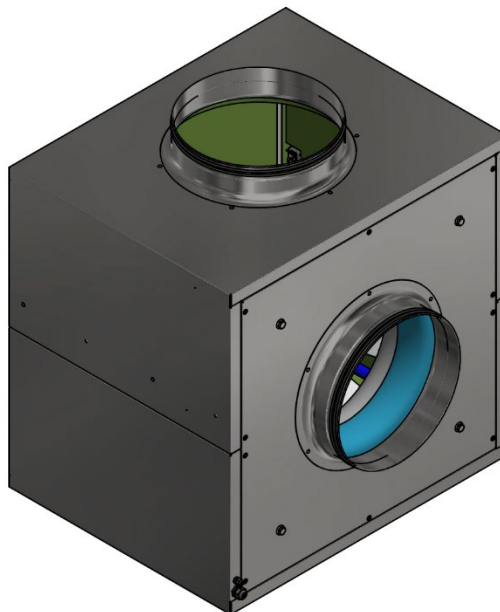

## Content

1.	SAFETY REGULATIONS AND INFORMATION .....	3
1.1	Hazard levels for warnings.....	3
1.2	Staff qualifications.....	3
1.3	Basic safety rules.....	3
1.4	Voltage.....	3
1.5	Safety and protective features .....	4
1.6	Electromagnetic radiation .....	4
1.7	Mechanical movement .....	4
1.8	Emissions.....	5
1.9	Hot surface.....	5
1.10	Storage .....	5
1.11	Disposal.....	5
1.12	Transport.....	5
2.	INTENDED USE .....	5
3.	TECHNICAL DATA.....	6
3.1	Product drawing .....	6
3.2	Nominal Data .....	7
3.3	Technical description.....	8
3.4	Mounting data .....	8
3.5	Electromagnetic compatibility .....	8
4.	CONNECTION AND STARTUP .....	8
4.1	Mechanical connection. ....	8
4.2	Electrical connection .....	9
4.3	Requirements .....	9
4.4	RCD .....	9
4.5	Connection diagram .....	10
4.6	Checking connections .....	11
4.7	Switching on the device .....	11
4.8	Switching off the device .....	11
5.	MAINTENANCE, MALFUNCTIONS, POSSIBLE CAUSES AND REMEDIES .....	11
5.1	Cleaning .....	11
5.2	Safety inspection.....	11
5.3	Troubleshooting .....	12

Read these operating instructions carefully before starting work on the device. Observe the following warnings to prevent malfunctions or danger to persons.

**These operating instructions are to be regarded as part of the device. The device is only to be sold or passed on together with the operating instructions.**

-//-

## 1. SAFETY REGULATIONS AND INFORMATION

### 1.1 Hazard levels for warnings

These operating instructions use the following hazard levels to indicate potentially hazardous situations and important safety regulations:



1.

#### **DANGER**

Indicates an imminently hazardous situation which will result in death or serious injury if the specified actions are not taken. Compliance with the instructions is imperative.

2.

#### **WARNING**

Indicates a potentially hazardous situation which can result in death or serious injury if the specified actions are not taken. Exercise extreme caution while working.

3.

#### **CAUTION**

Indicates a potentially hazardous situation which can result in minor or moderate injury or damage to property if the specified actions are not taken.

4.

#### **NOTE**

A potentially harmful situation can occur and, if not avoided, can lead to property damage.

### 1.2 Staff qualifications

5.

The device may only be transported, unpacked, installed, operated, maintained and otherwise used by suitably qualified, trained and authorized technical staff.

Only authorized specialists are permitted to install the device, to carry out a test run and to perform work on the electrical installation.

### 1.3 Basic safety rules

6.

The safety hazards associated with the device must be assessed again following installation in the final product.

7.

Note the following when working on the device:

Do not perform any modifications, additions or conversions on the device without the approval of ebmpapst.

### 1.4 Voltage

8.

Check the device's electrical equipment at regular intervals, including the potential equalization connection, cf. EN60204-1.

Replace loose connections and defective cables immediately.



9.

#### **DANGER**

Electrically charged device.

Risk of electric shock.

When working on an electrically charged device, stand on a rubber mat.

- 10. **WARNING**  
Live terminals and connections even with device switched off.  
Wait five minutes after disconnection the voltage at all poles before opening the device.
- 11. **CAUTION**  
If control voltage or a stored speed set value is applied, the motor will restart automatically, e.g. after a power failure.



- 12. **DANGER**  
Keep out of the device's danger zone.  
When working on the device, switch off the line voltage and ensure that it cannot be switched back on.  
Wait until the device comes to a stop.

## 1.5 Safety and protective features



- 13. **DANGER**  
Protective device missing and protective device not functioning  
Without a protective device there is a risk of serious injury, for instance when reaching into the device during operation.  
Operate the device with a fixed and insulating safety device as well as a secured protective net, if the unit is free-blowing or free-suctioning and is not connected to ducts. The protective net must be able to withstand the kinetic energy of an impeller part. The unit is a built-in component. You, the owner is responsible for providing adequate protection for the unit. Stop the device immediately if you detect a missing or ineffective safety device.

## 1.6 Electromagnetic radiation

- 14. Interference from electromagnetic radiation is possible, e.g. in conjunction with open- and closed-loop control devices.  
If impermissible radiation levels occur following installation, appropriate shielding measures must be taken by the user.

### NOTE

Electrical or electromagnetic interference after installing the device in customer equipment.  
Verify that the entire setup is EMC-compliant.

## 1.7 Mechanical movement



- 15. **DANGER**  
Rotation device  
Risk of injury to body parts coming into contact with the rotor or the impeller.  
Pay special attention to this if the unit is expected to be started without any associated ducting or safety devices.  
Secure the device against accidental contact.  
Before working on the system/machine, wait until all parts have come to a standstill.

## 1.8 Emissions



16. **WARNING**  
Depending on the installation and operating conditions, the sound pressure level may exceed 70 dB(A).  
Risk of noise-induced hearing loss  
Take appropriate technical safety measures. Protect operating personnel with appropriate safety equipment such as hearing protection.

## 1.9 Hot surface

17. **CAUTION**  
High temperature on electronics housing.  
Risk of burns.  
Ensure sufficient protection against accidental contact.

## 1.10 Storage

18. Store the device partially or fully assembled in a dry place, protected against the weather and free from vibration, in the original packaging in a clean environment. Protect the device against environmental effects and dirt until final installation. We recommend storing the device for no longer than one year from production date to guarantee trouble-free operation and the longest possible service life. The unit must be stored in the temperature range: -40°C to +80°C. Avoid shocks and bumps. When storing or installing, the product must be positioned so that it cannot function as a stepping-point for overhauling row spacing for other dangerous machines or installations.

## 1.11 Disposal

19. When disposing of the device make sure to comply with all relevant laws and regulations for the country of disposal.

## 1.12 Transport

20. Be careful, fragile content.  
Avoid bumps and shocks during handling as this can result in imbalance and broken bearings.

-//-

## 2. INTENDED USE

21. The device is exclusively designed as a built-in device for conveying air according to its technical data. For any other use, a new risk assessment should be made.

22. Intended use also includes:  
Moving ordinary clean air (all data is given at a density of 1.2 kg / m<sup>3</sup>). Operation of the unit with all necessary safety measures installed. Use according to the operating instructions.  
The product should not be used at speeds that excite the intrinsic frequencies in the cabinet and/or suspension as this will cause increased vibration and noise.

- 23. Improper use.  
Using the device under the following conditions is particularly critical and may pose a danger:  
Moving air containing abrasive particles.  
Move strongly corrosive air, e.g. salt fog. Exceptions to this are devices intended for use in salt mist and adequately protected under this application.
  
- 24. Moving air contaminated by dust, e.g. extraction of sawdust.  
Operation of the unit close to combustible materials or components.  
Operation of the device in an explosive atmosphere.  
Operation of the unit as a safety component, or as part of a safety-related function. Besides these, all applications that are not listed under proper use both during storage and during installation, the product must be positioned so that it cannot serve as a stepping-point for overlap of row spacing for other dangerous machines or installations.

-//-

### 3. TECHNICAL DATA

#### 3.1 Product drawing

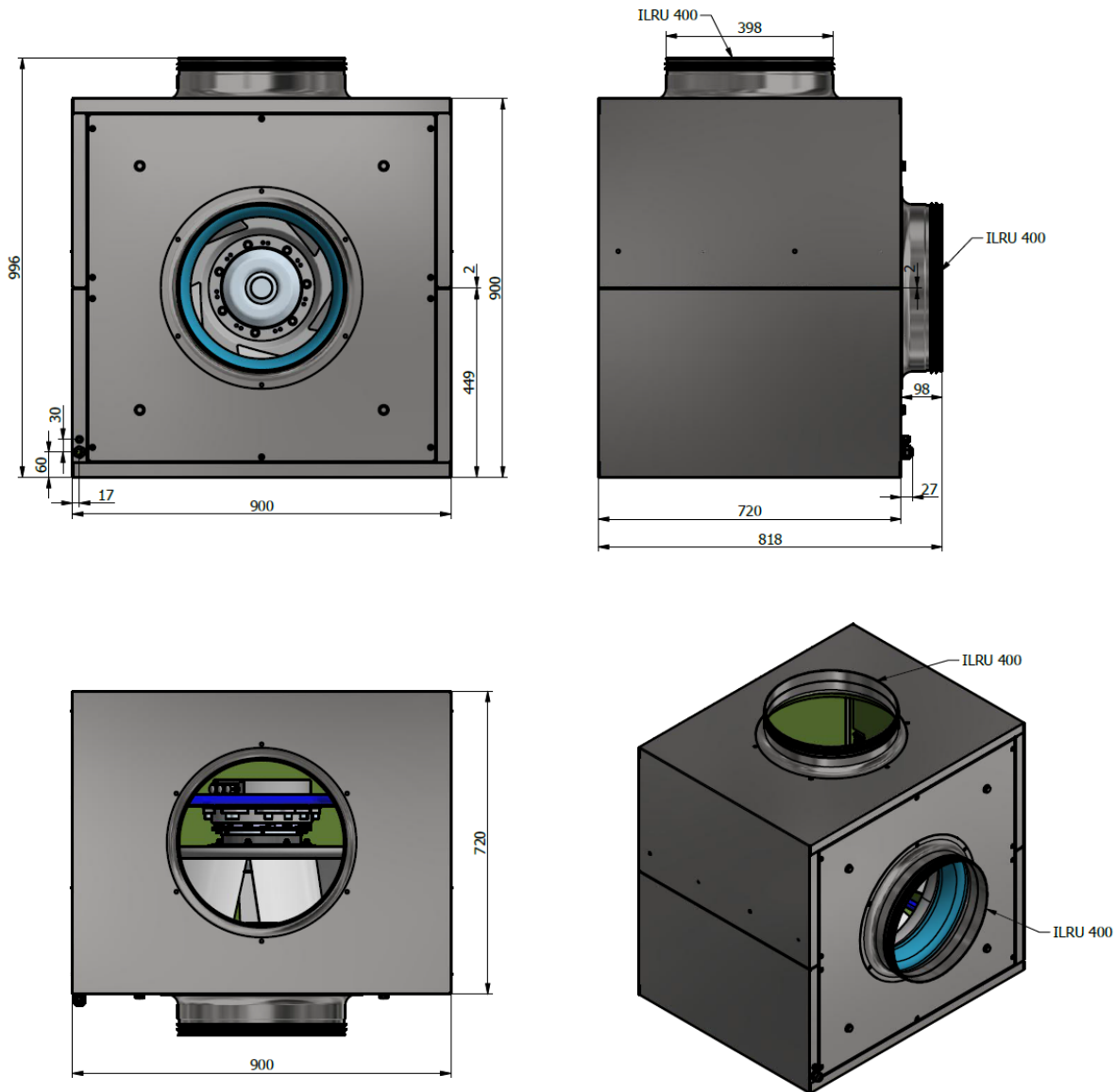

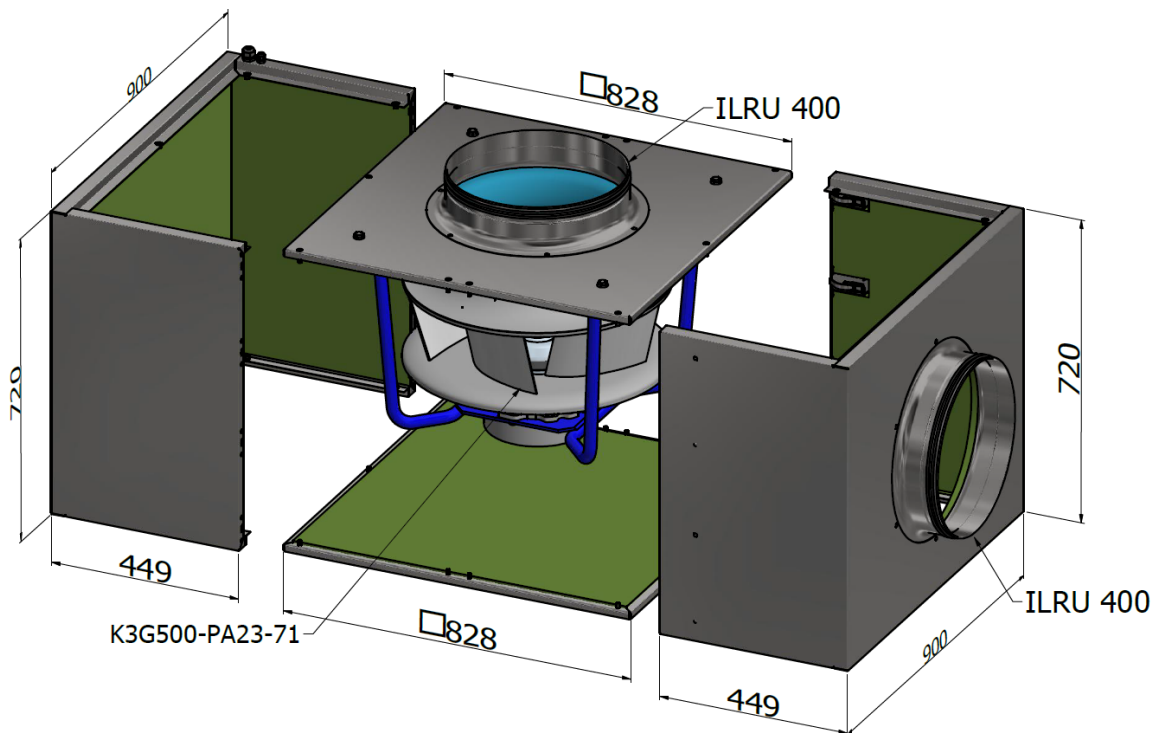

## 3.2 Nominal Data

25

Type: BoxFan BF500R900R-500PA2371

EC Fan: K3G500-PA23-71

Nominal voltage range: 380-480 VAC

Frequency: 50/60 Hz

Speed: 1910 RPM

Power input: 3450W

Current draw: 5,3 A (1)

Temperature range during operation: -25°C to +40°C

Max. airflow: 11.000 m<sup>3</sup>/h

Max. static pressure: 1350 Pa.

(1) Nominal data in working point with max. load at 400 VAC.

26

### Additional data:

PFC: Passive

LwA (Sound effect): 86 dB(A) (2)

LpA (Sound pressure at 1 m): 75 dB(A) (2)

LpA (Sound pressure at 3 m): 65 dB(A) (2)

(2) Nominal data for fan max. free-blowing at 0 Pa static pressure

Sound data measured i.h.t. ISO 13347

### Box data:

Weight: 83,7 Kg

Plate thickness chassis: 1 mm

Plate thickness, fan plate and inspection hatch: 3 mm

Insulation: 20 mm Polyethylen Cross Linked PE-Foam - LD-30, Black

Cable glands, PG: M12 and M20

Duct connection, ILU: Ø400

### 3.3 Technical description

- 27 Leakage: <3,5 mA i.h.t. IEC 60990  
Mode: S1  
Direction of rotation: Clockwise, viewed toward rotor  
Mounting position: Shaft horizontal or rotor on bottom; rotor on top on request  
Moisture: Condensation in motor and/or electronic housing must be avoided.  
Insulation class: B  
Condensation discharge holes: Rotor side  
Motor bearing: ball bearing  
Motor protection: Thermal overload protector (TOP) internally connected  
IP Class: IP55  
Protection class: I
  
- 28 Technical features:  
Control input 0-10 VDC / PWM  
Output 10 VDC, Max. 10 mA  
Over-temperature protected electronics / motor  
Tacho output, open collector, 1 pulse pr. revolt  
Motor current limitation  
Softstart

### 3.4 Mounting data

Secure the fastening device against unintentional loosening.

- 29 Perform electrical installations in accordance with 60204-1, especially device potential equalization connection and connections (60204-1 Section 8).
- 30 Prevention of accidental start-up shall be carried out in accordance with the rules of ISO 14118
- 31 Any emergency stop functions must meet the requirements of ISO 13850

### 3.5 Electromagnetic compatibility

- 32 EMC emission: EN 61000-6-3  
EMC Immunity: EN 6100-6-2  
Harmonic power feature: EN 61000-3-2/3
  
- 33 If several units are connected in parallel to the supply voltage so that the current here is in the level 16 - 75 A, then this arrangement is in accordance with. IEC 61000-3-12 so long that the short-circuit current  $S_{sc}$  at the connection point to the public grid is greater than or equal to 120 times the nominal consumption of the entire event.  
The installer, the Engineer or the Owner is responsible for ensuring, after dialogue with the supply network operator that the unit is only connected to a supply network with a short-circuit current value  $S_{sc}$  greater than or equal to 120 times the nominal consumption of the entire event

-//-

## 4. CONNECTION AND STARTUP

### 4.1 Mechanical connection.

- 34 CAUTION  
Risk of cutting and crushing when removing device from packaging  
Carefully remove the device from the packaging by grasping hold of the frame. Never subject to any impact.  
Wear safety shoes and cut-resistant safety gloves.  
If the machine is put into operation without associated ducting and safety precautions, there is a risk of

damaging body parts. Shields must therefore be established on both the suction and return sides in accordance with ISO 13857.

## 4.2 Electrical connection



### 35 DANGER

Voltage on the device  
Electric shock  
Always connect a protective earth first  
Check the protective earth



### 36 DANGER

Electrical charge (>50  $\mu\text{C}$ ) between phase conductor and protective earth connection after switching off supply with multiple devices connected in parallel.  
Electric shock, risk of injury  
Ensure sufficient protection against accidental contact. Before working on the electrical circuitry, short the supply and PE connections.

### 37 CAUTION

Voltage  
The fan is a built-in component and has no disconnecting switch.  
Only connect the fan to circuits that can be switched off with an all-pole disconnection switch.  
When working on the fan, secure the system/machine in which the fan is installed so as to prevent it from being switched back on.

### 38 NOTE

Electrical noise and consequent malfunction.  
Provide a gap between the supply cable and the control cable when installing these in the application.  
Provide adequate distance.  
Recommendation: distance > 10 cm (separate wiring).

### 39 NOTE

Water ingress into wires or cables.  
Water ingress at the customer end of the cable can damage the device.  
Make sure the end of the cable is connected in a dry environment.

40 Only connect the fan to circuits that can be switched off with an all-pole disconnection switch.

## 4.3 Requirements

41 Check whether the information on the nameplate matches the connection data.  
Before connection the device, make sure the power supply matches the device voltage.  
Only use cables designed for the current level indicated on the nameplate.

## 4.4 RCD

If your system requires the use of an FI relay, it is only permitted to use FI relays that are sensitive to all types of current (type B or B+). Personal protection is not possible with FI relays when operating the unit, as is the case with frequency inverters. When connecting the unit voltage supply, pulse-shaped charging currents from the capacitors in the integrated EMC filter can cause the activation of delayed release FI relays. We recommend fault current switches with a triggering threshold of 300 mA and delayed release (super-resistant, characteristic K).

## 4.5 Connection diagram

42

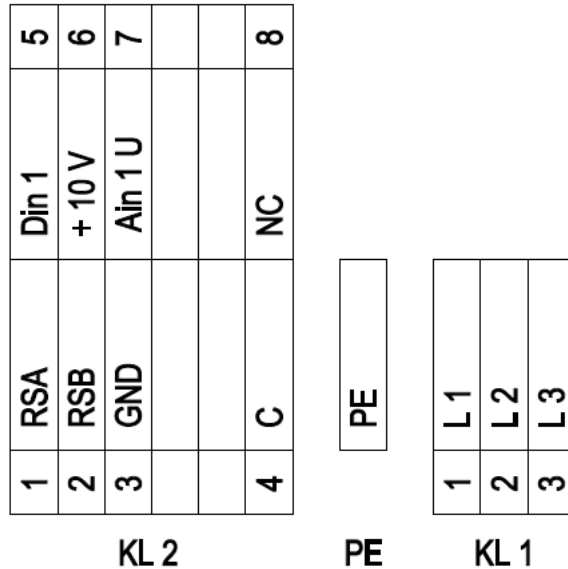

No.	Conn.	Designation	Function/assignment
KL 1	1	L1	Mains supply connection, supply voltage 3~380-480 VAC; 50/60 Hz
KL 1	2	L2	Mains supply connection, supply voltage 3~380-480 VAC; 50/60 Hz
KL 1	3	L3	Mains supply connection, supply voltage 3~380-480 VAC; 50/60 Hz
PE		PE	Earth connection, PE connection
KL 2	1	RSA	Bus connection RS-485, RSA, MODBUS RTU; SELV
KL 2	2	RSB	Bus connection RS-485, RSB, MODBUS RTU; SELV
KL 2	3	GND	Signal ground for control interface; SELV
KL 2	4	C	Status relay; floating status contact; break for failure; contact rating 250 VAC / max. 2 A (AC1) / min. 10 mA
KL 2	5	Din1	Digital input 1 enabling of electronics, enabling: open pin or applied voltage 5-50 VDC disabling: bridge to GND or applied voltage
KL 2	6	+ 10 V	Fixed voltage output 10 VDC; +10 V -3 %, max. 10 mA, short-circuit-proof, power supply for external devices (e.g. potentiometer); SELV Alternative: +24 VDC input for parametrisation via MODBUS without mains power
KL 2	7	Ain1 U	Analogue input 1 (set value) 0-10 V, Ri=100 kΩ, parametrisable curve; SELV
KL 2	8	NC	Status relay, floating status contact; break for failure

## 4.6 Checking connections

- 43 Ensure isolation from supply (all phases).  
Make sure a restart is impossible.  
Check the cables for proper fit.

## 4.7 Switching on the device



### WARNING

- 44 Understanding the product.  
Before using the product or after delivery or moving, make sure that the operator is familiar with these operating instructions and is familiar with the procedures for use, control and inspection of the machine.
- 45 Hot motor housing,.  
Risk of fire..  
Ensure that no combustible or flammable materials are located close to the fan.  
Before switching on, check the device for visible external damage and make sure the protective devices are functional.  
Apply the nominal supply voltage.  
Start the device by changing the input signal.

## 4.8 Switching off the device

- 46 Switching off the device during operation:  
Switch off the device via the control input to protect it.  
Do not switch the motor (e.g. in cyclic operation) on and off via power supply.  
Switching off the device for maintenance:  
Disconnect the device from the power supply.

-//-

# 5. MAINTENANCE, MALFUNCTIONS, POSSIBLE CAUSES AND REMEDIES

## 5.1 Cleaning

- 47 The fan is maintenance-free.  
Impeller cleaning is recommended only if subsequent proper balancing is performed.  
NOTE  
If the unit is damaged during cleaning, malfunctions are possible  
Do not clean the unit using water jets or high pressure washers.

## 5.2 Safety inspection

- 48 Every 6 months the following should be testes visually:  
Do all protective parts fit properly?  
Is the product damaged?  
Is the product fitted correctly?  
Are all cables fitted correctly?  
Is the product earthing properly fitted?  
Is the cable insulation defective?

## 5.3 Troubleshooting

- 49 The integrated protection features cause the motor to shut down automatically in the case of errors described below:

Malfunction	Possible cause	Possible solution
Motor not running	Mechanical blocking	Turn off, disconnect, and remove the mechanical blockage. Reset by disconnecting the power supply for at least 20 seconds after the motor comes to a stand-still.
Voltage failure	Check voltage	Restore supply
Connect control signal	Connection error	Correct connection. See connection diagram. Reset by disconnecting the power supply for at least 20 seconds after the motor comes to a stand-still
Thermal overload	Protection active	Let the unit cool off. Reset by disconnecting the power supply for at least 20 seconds after the motor comes to a stand-still
High electronic temp	Insufficient cooling	Improve cooling if possible. Reset by disconnecting the power supply for at least 20 seconds after the motor comes to a stand-still
High operating temperature	Lower temp. if possible	Reset by reducing control signal to 0 VDC
Impeller runs unevenly	Imbalance in rotating parts	Clean the unit and balance it properly. If imbalance is still present, the unit is replaced.

- 50 The machine cannot be repaired. Only original part is the fan. Therefore, return the unit to ebm-papst for repair or replacement.



- 51 **WARNING**

Terminals and connections have voltage even when the device is turned off.  
 Electrical shock.  
 Wait for 5 minutes after disconnection all connections before touching the unit.



- 52 **WARNING**

The machine is equipped with several electronic systems designed to protect the motor from overheating. These systems do NOT protect against accidental start. For manual intervention, service and repair switch must therefore be used.

- 53 **ATTENTION**

If the control signal is connected or a setpoint is stored, the motor will automatically restart, e.g. after a power failure. Risk of injury.  
 Stay outside the unit's danger zone.  
 When working on the unit, the supply voltage must be disconnected and it must be ensured that it does not connect again.  
 Wait for the unit to stop.

- 54 If the unit has not been used for an extended period of time, we recommend turning on the unit at least 2 hours before using it to remove any condensate, as well as moving the bearings.